

**EE-18 Exam 1**  
**Fall, 2003**  
**Prof. Traver**

Name: \_\_\_\_\_

1. In a building with 20 floors, we have an elevator controller that will use a binary code to represent individual floors.

a. What is the minimum number of bits required in the binary code? \_\_\_\_\_

b. Suppose we use 7-segment displays to show which floor the elevator is on. How many displays do we need? \_\_\_\_\_

c. If we design a decoder logic circuit to translate the binary code (in part a.) to the 7-segment code for the display (from part b.), how many inputs and outputs will this decoder have? Inputs: \_\_\_\_\_ Outputs: \_\_\_\_\_

2. a. Convert the decimal number 155.375 to a binary number. \_\_\_\_\_

b. Convert the binary number 11011111.01 to a decimal number. \_\_\_\_\_

3. a. Convert the binary number 10010101000001.11 to hexadecimal. \_\_\_\_\_

b. Convert the hexadecimal number 32F.2 to binary. \_\_\_\_\_

4. Write the truth table for the following function.

$$F = (a'b) \oplus (b+c)$$

5. Write an expression for the output G.

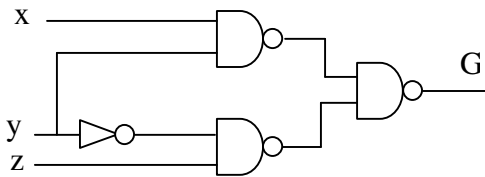

6. Find the canonical SOP expression for the following function:

$$F = (b + c)(a' + b')$$

7. Implement the following function using only NAND gates.

$$S = AB' + BCD + A'D$$

8. Write expressions for f and g as a function of the inputs a, b, and c.

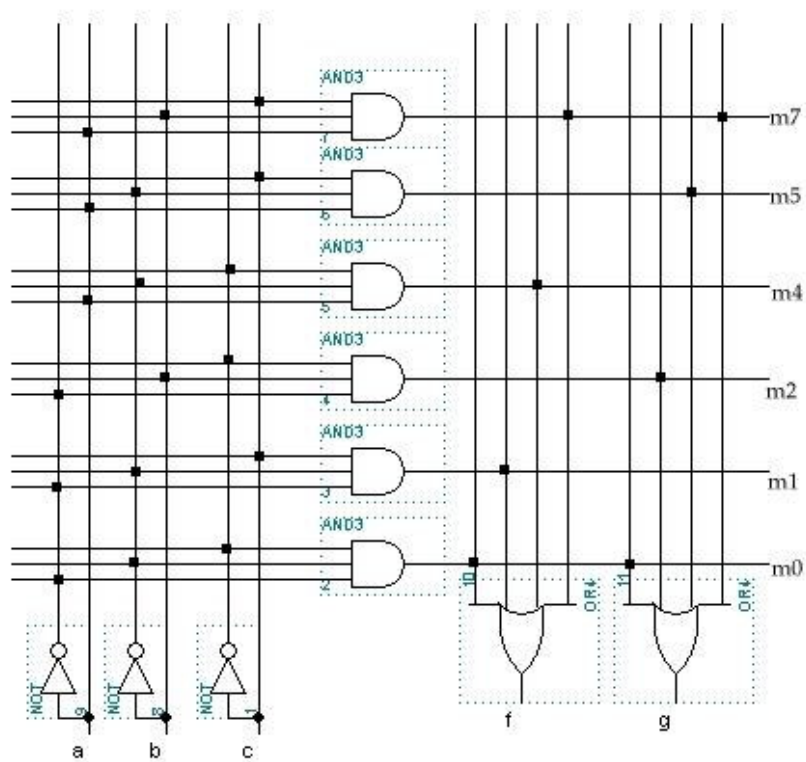

9. Find the simplest SOP form for the function, G, described by the following K-map.

	AB	00	01	11	10
C	0	0	1	1	0
	1	0	1	0	1

10. Use a K-map to simplify the following function.

$$F(a,b,c,d) = \sum m(2, 4, 6, 7, 10, 13, 14, 15)$$