

EE-18
Exam 1
Fall 1998
Prof. Traver

Name _____

1. (12 points) For the 8-bit string of ones and zeros given below:

10010101

a. Assume it is an unsigned binary number. Convert to decimal 149.

b. Convert to hex 95.

c. Assume it is a signed, 2's complement number and give the decimal equivalent -107.

d. What is the parity of this string? (odd or even) even

2. (10 points) Perform the arithmetic computations on the unsigned numbers shown below. Convert to decimal to check your answers.

110111	10000
+10111	- 1101
-----	-----
1001110	0011

3. (15 points) Given the function F below:

$$F = ABC' + A'B'C + BC$$

a. Find the truth table for F.

A	B	C	F
0	0	0	0
0	0	1	1
0	1	0	0
0	1	1	1
1	0	0	0
1	0	1	0
1	1	0	1
1	1	1	1

b. Find the shorthand sum of minterm expression for F.

$$F(A, B, C) = \sum m(1, 3, 6, 7)$$

or

$$F(A, B, C) = m1 + m3 + m6 + m7$$

c. Find an expression for the complement of F (F') in product of sum form by using DeMorgan's Theorem.

$$F' = (A'+B'+C)(A+B+C')(B'+C')$$

4. (12 points) For the function G given below:

$$G(W, X, Y) = \sum m(0, 1, 5, 7)$$

a. Draw a K-map for this function.

Ask in class if you have questions about this one. My drawing program is not cooperating to generate a graphical solution.

b. Draw circles around ALL prime implicants.

There were THREE prime implicants in the Kmap.

5. (14 points) For the function P given below:

$$P(A, B, C, D) = \sum m(0, 1, 3, 6, 7, 8, 9, 11, 14, 15)$$

a. Find a minimum sum of product expression for P.

$$P = BC + B'C' + B'D$$

b. Find a minimum product of sum expression for P.

$$P' = BC' + B'CD'$$

$$P = (B' + C)(B + C' + D)$$

6. (10 points) The figure below shows a 2-to-4 decoder module connected to a 4-to-1 multiplexor. The input signals A, B, C and D are connected to the select inputs of the decoder and multiplexor and the output of the multiplexor is the output of the circuit, F. Fill in the truth table for F.

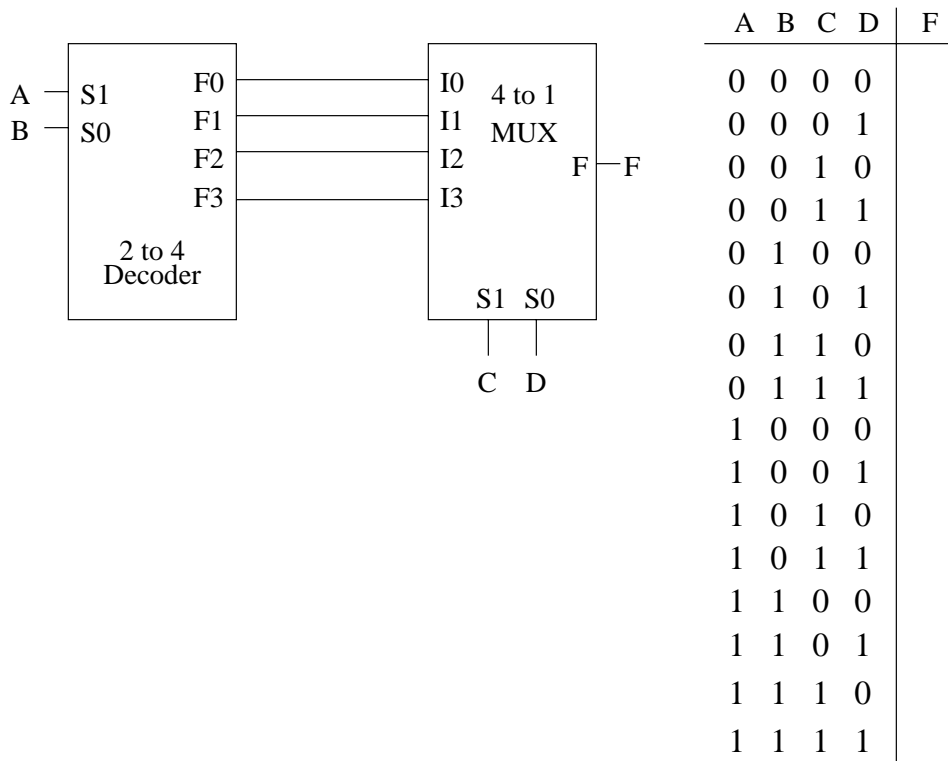

From top to bottom: F = 1000010000100001

7. (10 points) The 4 to 1 multiplexor below implements a function F with inputs A, B and C. Find an expression for F.

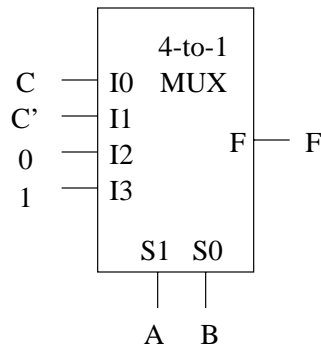

A B C F

0 0 0 0
0 0 1 1
0 1 0 1
0 1 1 0
1 0 0 0
1 0 1 0
1 1 0 1
1 1 1 1

$$F = \sum m(1, 2, 6, 7)$$

8. (16 points) Recall the full adder circuit module that was discussed in class.

The answer to this one is in the book and your notes! The symbol is a box with input labels A,B and Cin. The output labels are S and Cout.

a. Draw the symbol for a full adder.

b. Give the truth table for the full adder.

c. Give the equations for the two outputs of the full adder.

d. Show how 4 full-adder circuits are connected to form a 4-bit adder.

